

RWM | The New Stainless Steel S45



RWM's S45 Stainless Steel Casters feature a cold formed top plate, yoke and button that improves swivel action and increases service life with sealed raceways. The stainless steel casters are made of 304 stainless steel which is electropolished to a mirror finish to further improve long term corrosion protection and resistance to microbial buildup. Stainless steel casters provide a dramatic increase in resistance to corrosion due to environmental or chemical factors.

Popular Options Include:

- Stainless side actuating tread wheel brake (WBT)
- Total locking brake - locks wheel and swivel rotation (TL)
- High Temperature Lubrication (HT)
- Low Temperature Lubrication (LT)

Applications:

- Food processing plants & service equipment
- Meat processing facilities
- Healthcare & Hospitals
- Slaughter houses
- Fisheries
- Seafood processing plants
- Stock and maintenance carts
- Ingredient bins
- Institutional service carts and equipment
- Hatcheries
- Pharmaceutical plants and laboratories

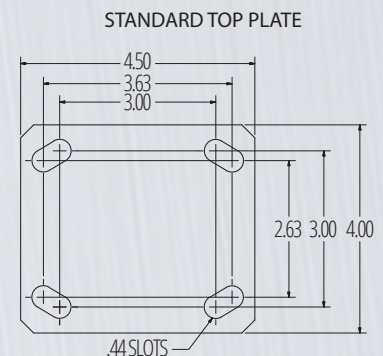

Mounting Plate Size: 4" x 4-1/2" x 1/4"
Bolt Hole Spacing: 2-5/8" x 3-5/8", slotted to 3"x3"

ENGINEERED TO OUTPERFORM

RWM Casters

1225 Isley Drive • Gastonia, NC 28052
Phone: 1-800-634-7704 • Fax: 1-800-253-6634

www.rwmcasters.com
customerservice@rwmcasters.com

The standard tight fitting raceway seals and polished stainless steel finish make this an ideal solution for messy food processing facilities, OEM equipment, cooking facilities, wash-down applications and medical facilities. These casters are available with side actuated tread locking brakes which provide superior locking over conventional side wheel brakes and are also offered in a total locking version which locks both the wheel and the swivel raceway from rotating at the same time.

WHEEL DIAMETER	WHEEL WIDTH	CAPACITY	WHEEL TYPE	OVERALL HEIGHT	ROLLER BEARING	BALL BEARING	PLAIN BEARING	SWIVEL LEAD	APPROX WEIGHT
4"	2"	350	Performance TPR	5-5/8"	S45-RPR-0420-S	S45-RPB-0420-S	S45-RPC-0420-S	1-3/8"	5.3
4"	2"	400	Signature	5-5/8"	S45-SWR-0420-S	S45-SWB-0420-S	S45-SWC-0420-S	1-3/8"	5.3
4"	2"	500	Polyolefin	5-5/8"	S45-POR-0420-S		S45-POC-0420-S	1-3/8"	4.8
4"	2"	500	Solid Urethane	5-5/8"		S45-MUB-0420-S		1-3/8"	5.2
4"	2"	600	Urethane Polypropylene	5-5/8"	S45-UPR-0420-S		S45-UPC-0420-S	1-3/8"	5.3
4"	2"	800	Durastan	5-5/8"	S45-DUR-0420-S		S45-DUC-0420-S	1-3/8"	5.2
4"	2"	800	High Temp Nylon	5-5/8"	S45-HNR-0420-S			1-3/8"	5.2
4"	2"	900	GT	5-5/8"		S45-GTB-0420-S		1-3/8"	5.2
5"	2"	375	Performance TPR	6-1/2"	S45-RPR-0520-S	S45-RPB-0520-S	S45-RPC-0520-S	1-11/16"	5.3
5"	2"	500	Signature	6-1/2"	S45-SWR-0520-S	S45-SWB-0520-S	S45-SWC-0520-S	1-11/16"	5.3
5"	2"	650	Polyolefin	6-1/2"	S45-POR-0520-S		S45-POC-0520-S	1-11/16"	4.9
5"	2"	750	Urethane Polypropylene	6-1/2"	S45-UPR-0520-S		S45-UPC-0520-S	1-11/16"	5.3
5"	2"	900	Durastan	6-1/2"	S45-DUR-0520-S		S45-DUC-0520-S	1-11/16"	5.4
5"	2"	900	GT	6-1/2"		S45-GTB-0520-S		1-11/16"	5.4
5"	2"	900	High Temp Nylon	6-1/2"	S45-HNR-0520-S			1-11/16"	5.4
5"	2"	900	Solid Urethane	6-1/2"		S45-MUB-0520-S		1-11/16"	5.4
6"	2"	525	Performance TPR	7-1/2"	S45-RPR-0620-S	S45-RPB-0620-S	S45-RPC-0620-S	2"	5.7
6"	2"	600	Signature	7-1/2"	S45-SWR-0620-S	S45-SWB-0620-S	S45-SWC-0620-S	2"	5.8
6"	2"	700	Polyolefin	7-1/2"	S45-POR-0620-S		S45-POC-0620-S	2"	5
6"	2"	900	Durastan	7-1/2"	S45-DUR-0620-S		S45-DUC-0620-S	2"	6.3
6"	2"	900	GT	7-1/2"		S45-GTB-0620-S		2"	6.3
6"	2"	900	High Temp Nylon	7-1/2"	S45-HNR-0620-S	S45-HNB-0620-S		2"	6.3
6"	2"	900	Solid Urethane	7-1/2"		S45-MUB-0620-S		2"	6.3
6"	2"	900	Urethane Polypropylene	7-1/2"	S45-UPR-0620-S		S45-UPC-0620-S	2"	5.7
8"	2"	600	Performance TPR	9-1/2"	S45-RPR-0820-S	S45-RPB-0820-S	S45-RPC-0820-S	2-9/16"	7.1
8"	2"	700	Signature	9-1/2"	S45-SWR-0820-S	S45-SWB-0820-S	S45-SWC-0820-S	2-9/16"	7.2
8"	2"	800	Polyolefin	9-1/2"	S45-POR-0820-S		S45-POC-0820-S	2-9/16"	5.8
8"	2"	900	Durastan	9-1/2"	S45-DUR-0820-S		S45-DUC-0820-S	2-9/16"	7.7
8"	2"	900	GT	9-1/2"		S45-GTB-0820-S		2-9/16"	7.7
8"	2"	900	High Temp Nylon	9-1/2"	S45-HNR-0820-S			2-9/16"	7.0
8"	2"	900	Solid Urethane	9-1/2"		S45-MUB-0820-S		2-9/16"	7.7
8"	2"	900	Urethane Polypropylene	9-1/2"	S45-UPR-0820-S		S45-UPC-0820-S	2-9/16"	7.7

To order a rigid caster, change the "S" to "R" in the model number. For example: "S45-DUR-0420-R". To order a rig only, omit the blue letters. For example: "S45-0420-S". Dimensions shown are nominal. If precise dimensions are required, consult your RWM representative. For approximate weight of our rigid casters, deduct 0.9 pounds per item.

ENGINEERED TO OUTPERFORM

RWM Casters

1225 Isley Drive • Gastonia, NC 28052

Phone: 1-800-634-7704 • Fax: 1-800-253-6634

www.rwmcasters.com

customerservice@rwmcasters.com